

FREEZER | Chestfreezers

CHEST FREEZER ► GLASS TOP

CFG 308

60 mm	C1 -18°C	D ENERGY CLASS	B +16°C/80RH +35°C/75RH
			GAS R290

DETAILS

 Castor included in the packaging (To be assembled)	 Digital thermometer	 Lock fitted as standard
 Basket included	 Top view of the unit	



GENERAL FEATURES

- 300 Lt. Chest freezer with sliding glass top
- White coated steel for external and internal
- Static Cooling
- Manual Defrost
- Digital thermometer
- Foaming Agent Cyclopentane (60mm per side)
- Single tempered safety glass
- Handle on the glass frame
- Lock fitted as standard
- Basket included (N.3 Pcs)
- N.4 Castor (N.2 in the front with brake)
- Energy efficiency class: D

TECHNICAL SPECIFICATIONS

Capacity	300 L
Temperature	C1 (-18°C)
Consumption	1.776 kWh/24h
Rated Power	179 W
Noise level	52.3 dB(A)
Net Weight	56 Kg
Gross Weight	70 Kg
External Dimensions (WxDxH mm)	1014x635x863
Internal Dimensions (WxDxH mm)	890x510x659
Packaging dimensions (WxDxH mm)	1100x750x860
Loading quantities 20'/40'/40'HQ	30/64/96

PRODUCT DIMENSIONS

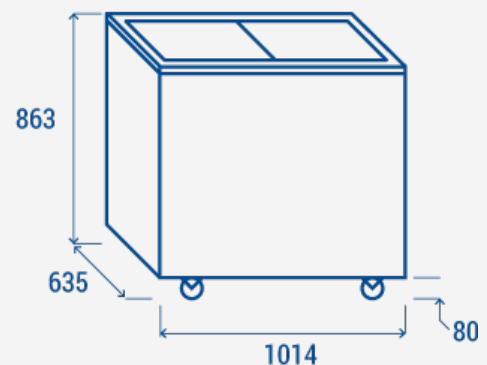

CERTIFICATION

CE RoHS

